

TM-330 Manual

Document List

Section	Description	File Name
	This Document 1 of 1	60899643.FM
	Declaration of Conformity	60899510.FM
Pitch Setting Guide	2 of 2	61124910.cdr
Table of Contents	1 of 1	60899814.FM
Safety Manual	Pages 1-4	60896311.FM
Operator's Manual	Pages 5-33	60896431.FM
Maintenance Instructions	Pages 34-36	60899412.FM
Exploded View	1 of 1	61269414.cdr
Additional Features	1-2	61004012.FM
Index	1-2	60899912.FM
I/O Port	Pages 1-6	61078916.FM
Low Cover Tape Sensor	Pages 1-3	61158411.FM
Service and Parts Contacts	1 of 1	61053911.FM
	Cover and Back	60900111.FM

DECLARATION OF CONFORMITY

Model: TM-330
Serial: _____
Date: _____

This product complies with the following European Union Directives:

89/392/EEC Machinery
as amended by 91/368/EEC, 93/44/EEC

89/336/EEC Electromagnetic Compatibility
as amended by 92/31/EEC, 93/68/EEC

The following standards were used to verify compliance with the Directives:
EN292, EN23742, EN60204

Approved by: _____



Engineering

ISO 9001 #46361
Certified by BVQI

TM-330

Table of Contents

Safety Instruction - - - - -	1
Safety Introduction - - - - -	2
Safety Marking Definitions - - - - -	3-4
Operator's Instructions - - - - -	5
Assembling Procedure - - - - -	6
Description of Components- - - - -	7-10
Controller Operation - - - - -	11-13
Setup - - - - -	14-30
Operation - - - - -	31-33
Maintenance Instructions - - - - -	34-36
Exploded View - - - - -	1 of 1
Additional Features - - - - -	1-2
Index - - - - -	1-2
Additional Features - - - - -	1-6
Low Cover Tape Sensor - - - - -	1-3
Service and Parts Contract - - - - -	1

TM-330

Safety Instructions

These instructions describe the procedures you must follow to safely operate the TM-330. Read all instructions before operating the TM-330, and keep them for future reference.

Safety Introduction

In these instructions you will find:

- Important definitions of safety markings
- Important safety guidelines to follow when operating the TM-330

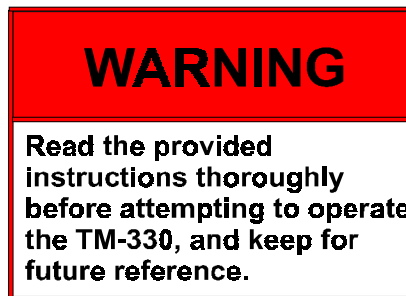

The intended use of the TM-330 Taping Machine is to place surface mount components into carrier tape. Use of this equipment in any other fashion may lead to personal injury.

The safety guidelines provided on the following pages are intended to educate the user on all safety issues in order to operate the TM-330 safely.

Pay close attention to these statements as they contain important information on avoiding potential hazards to yourself or to the equipment.

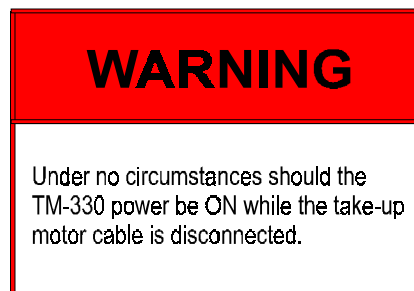
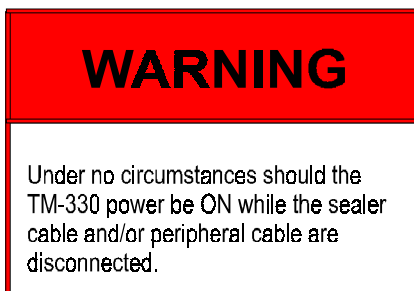

Safety Marking Definitions



Attention

This mark is placed on the equipment near an adjustment or danger zone.

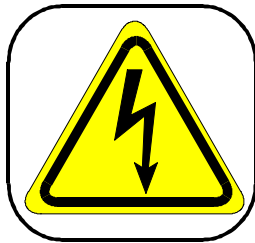

Dangerous Voltage

This mark indicates potential hazards arising from dangerous voltage.



High Temperature

This mark indicates a hot surface.



Crushed Hand

This mark is placed near areas that can cause personal injury or equipment damage if unsafe practices are used.



Open Book

Refer to the Maintenance Instructions before performing maintenance procedures on the TM-330.

Safety Marking Definitions (cont.)



Warning

Used when there is a risk of physical injury to people around the machine.



Caution

Used when there is a risk of damage to the TM-330.

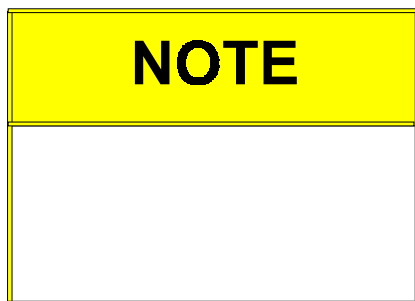

Note

Used to call your attention to important information.

TM-330

Operator's Instructions

These instructions describe the operation of the TM-330. Read all instructions before using the TM-330, and keep for future reference.

Operator's Instructions Contents

Assembling Procedure	6
Description of Components	7
Controller Operation	11
Setup	14
Operation	31

Assembling Procedure

Refer to Figure 1 for the information below.

Equipment Required:

3/16" hex wrench
5/32" hex wrench
80 PSI air pressure system

Figure 1

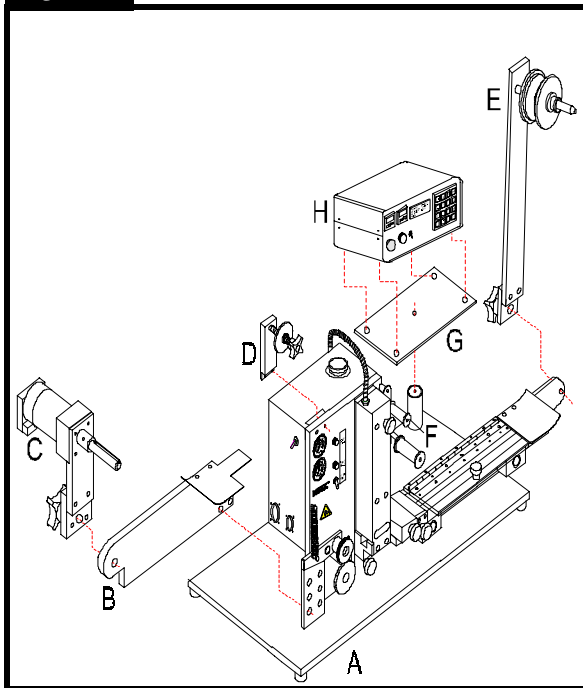

Baseplate Assembly (Ref. A)

Assembled prior to shipping.

Follower Track Support Arm (Ref. B)

Using the 3/16" hex wrench, attach the support arm to the baseplate with the five bolts provided.

Take-Up Reel Drive Arm (Ref. C)

Remove the black knob from the follower track support arm (Ref. B). Slide the take-up reel drive arm onto the threaded rod, position it at about 45° away from the baseplate assembly, and secure with the black knob.

Cover Tape Reel Support (Ref. D)

Using the 5/32" hex wrench, attach the cover tape reel support to the seal assembly upright plate with the two bolts provided. Remove the protective paper from the cover tape front and rear covers and assemble as shown on page 14.

Feed Reel Support Arm (Ref. E)

Remove the black knob from the loading track support arm (right side). Slide the feed reel support arm onto the threaded rod, position it at about 45° away from the baseplate assembly, and secure with the black knob.

Cover Tape Guide #1 (Ref. F)

Loosen the screw holding the tape guide (5/32" hex wrench) and position at a 45° angle. Tighten screw.

Note: Extended cover tape guides are removed for shipping and must be attached using a 5/32 inch hex wrench.

Control Module Baseplate (Ref. G)

Slide the control module baseplate into the pedestal.

Control Module (Ref. H)

Place the control module on the control module baseplate. Connect all cables to the matching connectors.

Description of Components

Refer to Figure 2 for the information below.

Figure 2

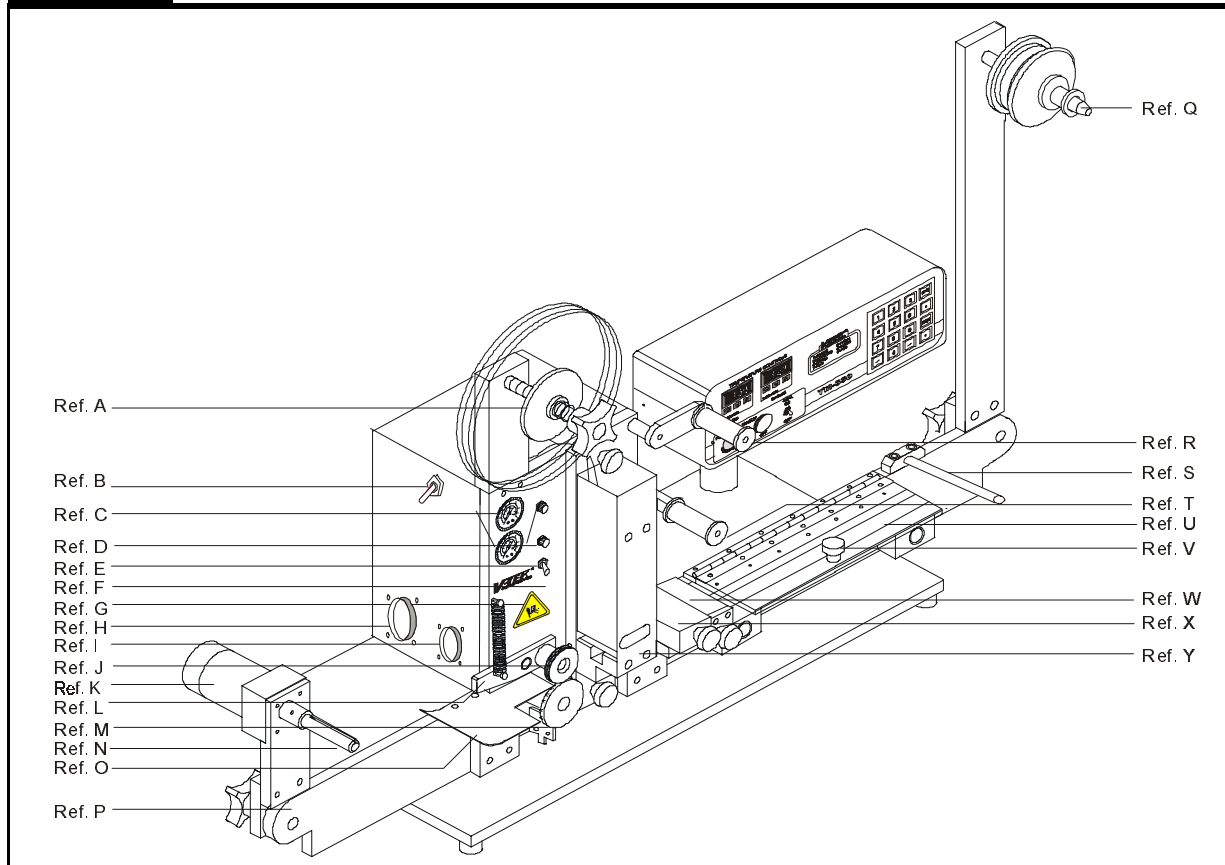

Tape Reel Spindle (Ref. A)

Holds the bulk reel of cover tape and provides appropriate tension to the cover tape.

Sealer Cooling (Ref. B)

Cools the tape when the machine is not performing a cycle.

Seal Pressure Gauges (Ref. C)

Monitor the pressure applied to the heat shoes during the sealing process.

Seal Pressure Adjust Controls (Ref. D)

Set the amount of pressure applied to the heat shoes during the sealing process.

Air Pressure ON/OFF Switch (Ref. E)

Turns the air pressure to the sealer ON or OFF.

Seal Assembly/Motor Upright Plate (Ref. F)

Supports the air pressure gauges, seal assembly, and drive motors.

Crushed Hand Sticker (Ref. G)

This sticker is placed near areas that can cause personal injury or equipment damage if unsafe practices are used.

Peripheral Plug-In (Ref. H)

Connect to the rear panel of the controller to connector J2-3.

Description of Components

Refer to Figure 2 for the information below.

Take-Up Motor Plug (Ref. I)

Connects to the take-up reel drive motor (Ref. K) to the machine.

Idler Wheel (Ref. J)

Holds the carrier tape firmly to the drive sprocket.

Take-Up Reel Drive Motor (Ref. K)

Applies tension to the filled carrier tape as the tape is wound on the take-up reel.

Idler Arm (Ref. L)

Holds the sealed tape against the drive sprocket.

Drive Sprocket (Ref. M)

Powered by the drive motor, the drive sprocket pulls the carrier tape through the TM-330 by engaging the sprocket holes in the tape.

Take-Up Reel Spindle (Ref. N)

Holds the take-up reel and applies tension to wrap the filled carrier tape onto the take-up reel.

Tape Guide #3 (Ref. O)

Guides the filled carrier tape to the take-up reel.

Follower Track Support Arm (Ref. P)

Supports the follower track, carrier tape guide #3, and take-up reel drive arm.

Carrier Tape Quick Lock (Ref. Q)

Holds the reel of carrier tape on the spindle.

Cover Tape Guide #1 (Ref. R)

Supports and guides the cover tape.

Front Tape Guide (Ref. S)

Guides the bulk carrier tape into the loading track.

Cover Tape Guide #2 (Ref. T)

Helps guide the cover tape into the sealing mechanism.

Adjustable Loading Track (Ref. U)

Area where parts are placed in the carrier tape. The outside edge of the track can be moved to preset positions which will accommodate most tape widths.

Parts Cover (Ref. V)

Removable, see-through cover which allows the operator access to parts which have been placed in the carrier tape.

Carrier Tape Guide (Ref. W)

Guides filled carrier tape to heat shoes.

Cover Tape Guide #3 (Ref. X)

Adjustable guide for precisely positioning the cover tape over the carrier tape prior to sealing.

Heat Sealer Assembly (Ref. Y)

Controls the heat shoes with three variables: time, temperature, and pressure. The assembly is interchangeable for different tape widths.

Description of Components

Refer to Figure 3 for the information below.

Figure 3

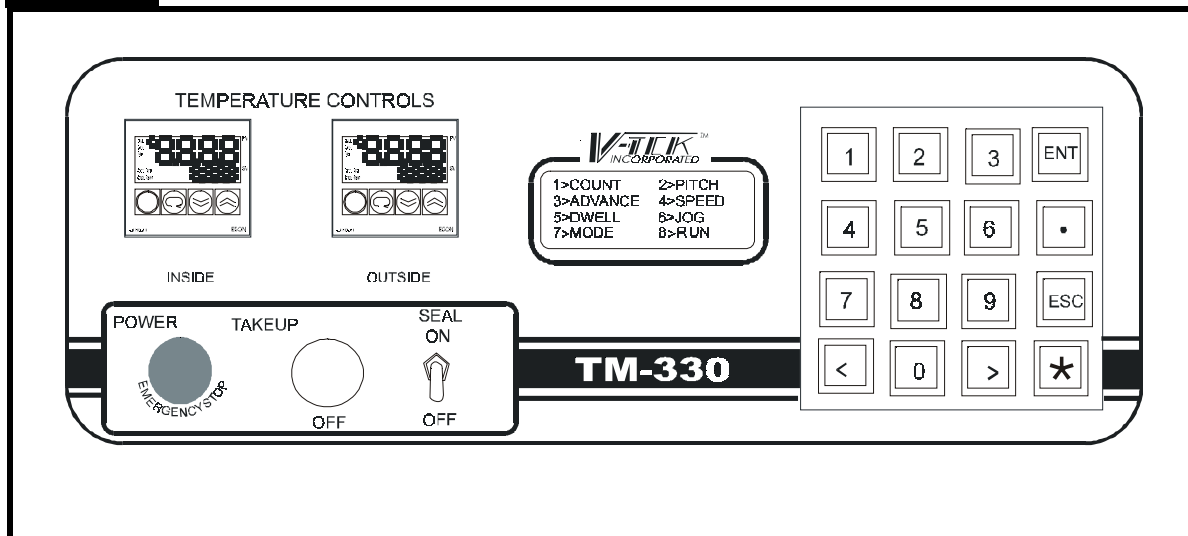

Power Switch

The main power switch for the TM-330 controller provides power to the counter, take-up motor, sealer and drive motor. Pull the knob out to turn power ON and push in to turn OFF. This switch is also used for emergency stopping.

Take-Up Tension

Adjusts the torque applied to the filled tape as it is wrapped onto the take-up reel. Turn the knob clockwise to increase the tension. Apply only as much tension as needed to wrap the tape onto the reel. Adjustments may need to be made due to differing sizes and weights of taped components.

Seal ON/OFF Switch

When set to ON, the heat seal is enabled. When set to OFF, the heat seal is disabled. The heat seal switch must be OFF when using a PSA sealer.

Temperature Controls

The temperature controls set the temperature of the heat shoes to a level that will cause the heat sensitive adhesive on the cover tape to melt. There are two separate controls:

Inside is the seal head closest to the sprocket side of the carrier tape.

Outside is the seal head closest to the outside edge of the carrier tape as viewed facing the machine.

LCD Display

Displays the menu and parameters chosen.

16 Button Keypad

Used to enter and select the parameters.

Description of Components

Refer to Figures 4 and 5 for the information below.

Figure 4

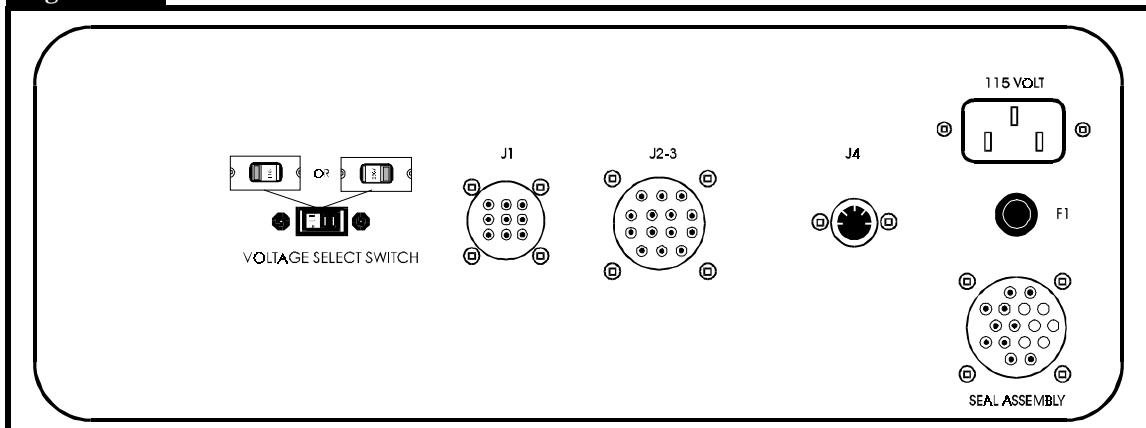
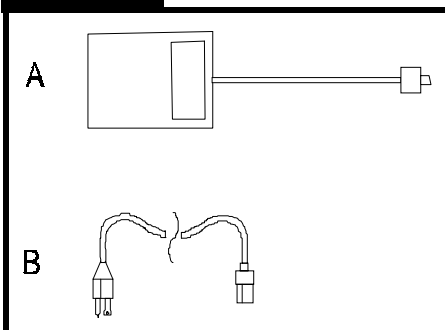

Figure 5



Voltage Select Switch

Set the voltage select switch to either 115V AC or 230V AC, depending on the type of AC input power that is supplied to the TM-330.

Connector J1

Used to connect the TM-330 to various autoseed mechanisms (optional).

Connector J2-3

Connects the TM-330 controller to the peripheral drives and sensors on the machine (Fig. 2, Ref. H).

Connector J4

Connects the foot switch (Fig. 5, Ref. A) to the TM-330 controller.

Power In (115 VOLT)

Receptacle for connection (Fig. 5, Ref. B) to 115 volt, 50-60 Hz. supply.

Fuse (F1)

The TM-330 uses a 1.5 amp fuse, type 3AG, for 115 volt, 50-60 Hz. line power.

Seal Assembly Connector

Connects the heat seal assembly to the temperature controllers.

Controller Operation

Machine Identification Screen

```
*****
*           VTEK           *
*           TM-330        *
*****
```

Setup Choices Screen

```
1>COUNT  2>PITCH
3>ADVANCE 4>SPEED
5>DWELL   6>JOG
7>MODE    8>RUN
```

1>COUNT Screen

```
1>Reset count to 0
2>Preset stop value

STOP IS NOW      2500
```

1>COUNT

Choice 2>Preset Stop Value

```
Enter parts count
STOP value then ENT

_____
```

General Controller Information

The TM-330 controller is microprocessor operated and menu driven. All operational parameters, except temperature control and take-up tension, are chosen through a menu system. There are seven selection screens that provide the operator the ability to select the appropriate parameters. There is also a run screen that displays all chosen parameters and keeps a running parts count total.

At power-up, the microprocessor will restore all parameter values with which it was operating at the time of shutdown. An intentional or accidental shutdown will cause the microprocessor to store all current values that it has into non-volatile memory. This includes the total parts count. During operation, the system compares the running parts count to the preset stop value. Upon reaching the stop value, the machine is halted and a message is displayed.

Controller Operation

Pull the TM-330 controller power button out to turn it ON. Upon power-up, the first screen that appears is the machine identification screen. Pressing any key will replace this screen with the setup choices screen. The setup choice screen offers five items that can be adjusted, a jog forward or reverse option, and a choice that goes directly to the run screen.

1> COUNT

Choosing this will offer two (2) choices: (1) clear the current parts count total, or (2) preset the parts count at which the system is to stop. The stop point has an upper limit of 999,999 parts. The current stop value is displayed for reference.

To clear the parts count press 1 and then ESC. To enter a preset stop value press 2, insert the number and press ENT.

Controller Operation

2> PITCH

PITCH (mm)		
1> 4	2> 8	3>12
4>16	5>20	6>24
7>28	8>32	9>OTHER

2>PITCH

Enter the Pitch
(1-144 mm) then
'ent'

9>OTHER

3>ADVANCE

Enter the number of
parts to advance
then "ent"

4>SPEED

ENTER SPEED 5 - 250
THEN PRESS ENTER

5>DWELL

Enter Dwell Time
from 50 to 999mS
then press ENT

2>PITCH

This menu offers eight preset pitch choices. It also offers entry into another screen that allows the user to enter a pitch of their own choosing.

Choose a preset value for the pitch by entering the number to the left of the pitch value, this will return you to the menu. If the value is not listed press 9. Enter the pitch value then press ENT.

3>ADVANCE

This screen prompts the user to enter the number of parts to advance each time the foot switch is pressed or an advance pulse command is programmed into the I/O port. The user can choose any value up to the maximum allowed. If an invalid value is chosen, the software will ask for another choice. The maximum is determined by the software. The length of loading track in relation to the pitch is the determining factor. Enter the number of parts you would like advanced then press ENT.

4>SPEED

This screen asks the user to enter the desired speed level using the keyboard. Any speed level between 5 and 250 is acceptable.

Pressing the ENTER key will lock in the speed choice and return user to the setup menu. If escape is pressed from this screen, without pressing the ENTER key, the current speed will continue to be used.

5>DWELL

This screen allows the operator to adjust the length of time that the heat shoes remain on the tape. Any value between 50 milliseconds and 999 milliseconds may be entered. Enter the dwell time in the space provided and press ENT. Not applicable when pressure sealing.

Controller Operation

6>JOG

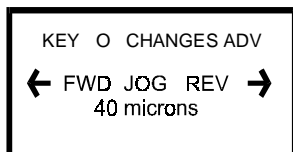

7>MODE

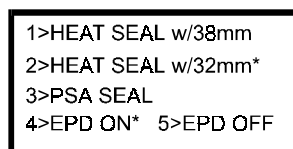

8>RUN

Pitch	Advance	Dwell
8	10	PSA
Speed	Stop	Count
6	1000	945

6>JOG

This is used to adjust the initial positioning of the tape, prior to running. The default advance distance is 40 microns (.0016 inches). Pressing 0 changes the advance distance to 2 mm. Pressing 0 again returns it to 40 microns.

Use the arrow keys on the keypad to choose forward or reverse, then press ESC to exit.

7>MODE

This screen offers the option of running the system with either a heat sealer or a pressure sensitive tape sealer, with empty pocket detection ON or OFF (if present).

Changing from heat to PSA will affect the machine operation in a few ways. In the pressure mode, the method of tape advance is changed to maximize throughput. No dwell time is involved. Note that when in the heat mode, the dwell time value is displayed onscreen. If the system is switched to the PSA mode the heat seal switch can be turned OFF. The dwell time value display will be replaced by the letters PSA. Also when in the pressure mode, the temperature failure alarm is not active.

The user may choose the newer 38mm heat shoes or the older 32mm heat shoes. An asterisk will be displayed indicating the current shoe length chosen.

To choose heat sealing press 1 or 2 depending on the heat shoes. To choose PSA press 3.

The EPD choice allows the empty pocket detector to be enabled or disabled. If no empty pocket detector is installed, this choice is inactive.

An asterisk will be displayed near the current mode choices.

8>RUN

This choice will place the system in an operating state. All choices will be displayed on a single screen along with the running parts count. The system is now ready to be activated by an advance command.

Setup - If Using Heat Sealer

Refer to Figures 6 and 7 for the information below.

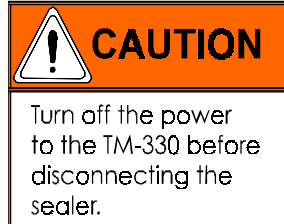

Figure 6

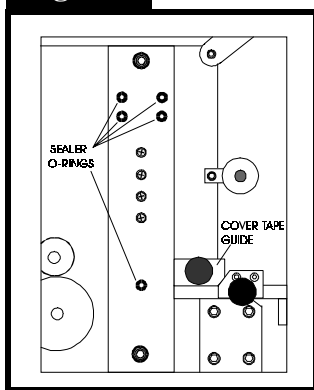
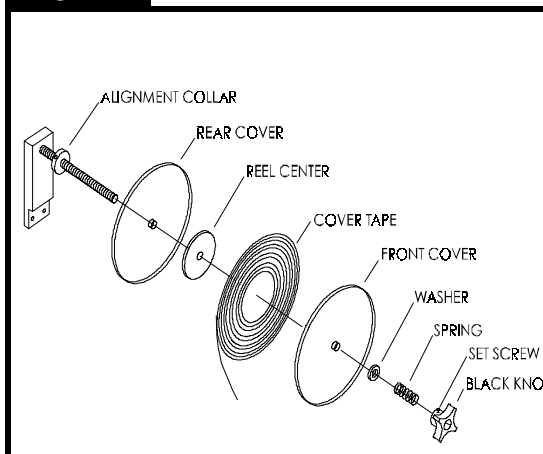

Figure 7



Mount Heat Sealer Assembly

A sealer must be used which matches the width of the carrier tape being used. To remove an existing sealer, turn the sealer air pressure switch OFF, disconnect the sealer connector, and remove the two bolts which secure the sealer to the upright plate. Carefully lift the sealer away from the upright plate.

Mount Heat Sealer Assembly (cont.)

When mounting a new sealer, first inspect the upright plate where the sealer is mounted to make sure all of the o-rings are in place. There are five o-rings at the places shown which must be in place for the sealer to function properly. Replace any missing or damaged o-rings. A small amount of glue can be used to secure the o-rings in their holes if they are replaced. Carefully lower the new sealer into position. Do not hit the exposed corners of the loading track with the sealer or they may be damaged. Run the sealer connector and cord over the top of the upright plate and align the pins of the connector with the receptacle on the back of the controller before plugging it in. Secure the sealer with its two mounting bolts.

There is a cover tape guide which accompanies every sealer. When changing sealers, this guide must also be changed. To do so, remove the knurled, metal knob which secures it in place and slide the guide straight off. Once the new sealer is in place, mount the new cover tape guide, making sure its marked tape width matches that of the sealer.

Load the Heat Sealer Cover Tape

Remove the large black knob from the cover tape spindle (loosen the brass set screw if necessary). Remove the spring, washer, and front plastic cover from the spindle. Place a reel of cover tape (correct width to match the carrier tape) on the reel center, so the tape unwinds to the right from the bottom of the reel. Replace the plastic cover, washer, spring, and black knob. Tighten the knob until there is some tension on the cover tape as it unwinds, but make sure the tension is not excessive. Tighten the brass set screw on the black knob to secure it in place.

Setup - If Using Heat Sealer (cont.)

Refer to Figures 8 and 9 for the information below.

Figure 8

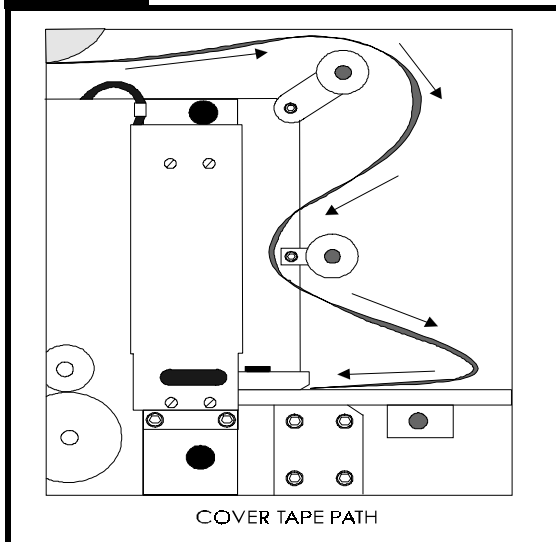
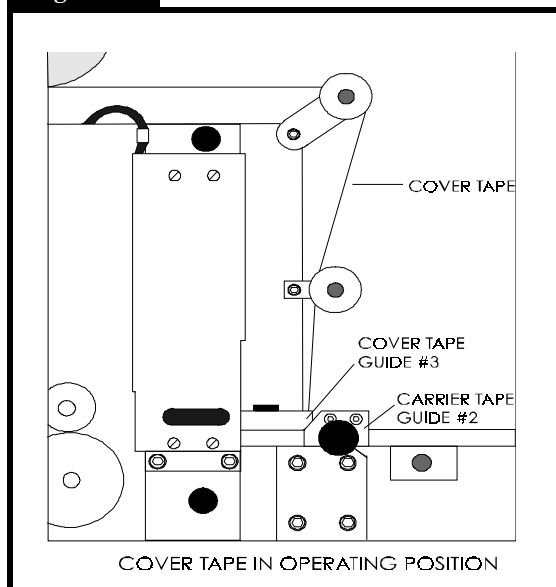

Figure 9



Load the Carrier Tape

Remove the carrier tape quick lock from the hub and mount the bulk carrier tape reel on the hub (the sprocket holes on the carrier tape must be on the inside). Replace the quick lock and position it so the reel is supported and spins freely on the spindle. Trim the end of the carrier tape so it is clean and straight.

Load the Carrier Tape (cont.)

The loading track is adjustable for tape width. Set the track width to match the sealer mounted on the TM-330 by pulling out, or pushing in, evenly on both ends of the track. There are detents which will cause the track to lock in at each tape width.

Open the parts cover by lifting on the black knob and remove carrier tape guide #2 by unscrewing its black knob.

Guide the carrier tape under carrier tape guide #1 and into the loading track. The carrier tape should feed through the loading track easily. Lower the feed reel support arm if necessary to allow the tape to feed more easily into the loading track. Bring the end of the tape just up to cover tape guide #3.

Load Tapes into Sealer

Pull the cover tape down through the cover tape guides as shown. Pull about 12" of cover tape out and lay it over the carrier tape, with the free end pointing toward the sealer. The shiny side of the tape should be up. Allow about 2" of the free end of the cover tape to hang over the end of the carrier tape. Push the tapes under the cover tape guide and through the sealer by pushing on the carrier tape. Keep enough slack in the cover tape so it follows the carrier tape through the sealer.

Lift the idler wheel by pushing down on the left side of the arm. Align the sprocket holes in the carrier tape over the pins on the drive sprocket. Straighten the cover tape so it is aligned with the carrier tape and rewind any remaining slack back onto the cover tape reel. Position the cover tape so it is running in the groove in cover tape guide #3. Replace carrier tape guide #2 and screw it down. Close the parts cover.

Setup - If Using Heat Sealer (cont.)

Mount Take-Up Reel

Mount an empty take-up reel on the take-up reel spindle. The width of the reel must match the width of the carrier tape and the reel must be big enough around to accommodate the number of components in the taping job.

General Seal Setting Information

The cover tape peel force is determined by four factors at the time the cover tape is sealed to the carrier tape.

These four factors are:

1. The width of the sealing track on the heat seal shoe.
2. The pressure applied to the seal area.
3. The dwell time, or heating time that the heat shoe is pressing on the cover tape.
4. The temperature of the seal assembly.

All four of the factors may be varied on the TM-330 but only the dwell time, seal pressure, and temperature setting changes are usually required. The seal width is selected at the factory and should only require changing under unusual circumstances. The settings in the chart are good general starting points to be used when first learning to use the TM-330. Experience will suggest variations from these settings that will provide the desired seal characteristics as determined by a peel force test.

APPROXIMATE STARTING POINTS FOR SEAL CONTROLS

CARRIER TAPE TYPE	COVER TAPE TYPE	TEMPERATURE IN CELSIUS	PRESSURE IN PSI	DWELL TIME IN MILLISECONDS
3M TYPE 3000 CONDUCTIVE CARRIER	3M TYPE 2675 CONDUCTIVE COVER	180°	40	300
3M TYPE 2701/2703 NON-CONDUCTIVE CARRIER	3M TYPE 2675 NON-CONDUCTIVE COVER	180°	40	300
3M TYPE 2701/2703 NON-CONDUCTIVE CARRIER	3M TYPE 2675 NON-CONDUCTIVE COVER	180°	40	300
3M TYPE 3000 CONDUCTIVE CARRIER	3M TYPE 2675 NON-CONDUCTIVE COVER	180°	40	300
ADVANTEK CONDUCTIVE CARRIER	ADVANTEK TYPE AA COVER	150°	40	300
ADVANTEK NON-CONDUCTIVE CARRIER	ADVANTEK TYPE S COVER	160°	40	300

Use this chart as a guide for setting the controls for the first time. These values may need to be altered due to variations in lot materials and customer requirements.

Setup - If Using Heat Sealer (cont.)

Refer to Figure 10 for the information below.

Figure 10

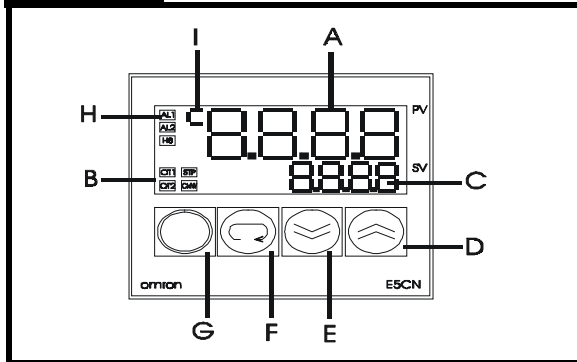

Description of Temperature Controllers

Use the information below for operating the temperature controllers (Fig.10, Ref. A and B).

DISPLAY (Ref. A)

Shows the current temperature. The display changes each time the Return key is pressed.

OPERATION INDICATORS (Ref. B)

Light up when a certain operation is being performed. Each of the three are explained below:

CMW- Not used

STP- Not used

OUT- Lights up when the temperature controller is ON.

SET POINT DISPLAY (Ref. C)

Displays the set or target temperature.

INCREMENT KEY (Ref. D)

When pressed, increases the selected value. Successively increases the value when held down.

DECREMENT KEY (Ref. E)

When pressed, decreases the selected value. Successively decreases the value when held down.

RETURN KEY (Ref. F)

Each time pressed, changes the readout on the display

LEVEL KEY (Ref. G)

Pushing this key once and holding it down for 5 seconds will reset the Controller. To change the level, press and hold the level key along with the return key.

ALARM INDICATOR (Ref. H)

If present temperature exceeds or falls below the set temperature, by the alarm value, this indicator will light.

°C / °F TEMPERATURE DISPLAY (Ref. I)

Indicates the temperature measurement shown on the display.

Operation of Temperature Controllers

SETTING TARGET TEMPERATURE

To set the target temperature, simply use the Increment and Decrement keys to adjust the set point display (Ref. C).

ALARM FUNCTIONS

Alarm Value- To set, press the Return key until the screen reads *AL-1*. Next, set the alarm value by using the Increment and Decrement keys.

Alarm Limits- To set the alarm value upper limit, press the Return key until the display reads *AL-IH*. Next, set the upper limit by using the Increment and Decrement keys. To set the lower limit press the Return key until the display reads *AL-IL*. Set the lower limit by using the Increment and Decrement keys.

Setup - If Using Heat Sealer (cont.)

Operation of Temp. Controllers (cont.)

SETTING UPPER AND LOWER LIMITS

To set the upper and lower limits, change levels by pressing the Level key (Ref. G) and holding down for at least 3 seconds until the display changes. Set the upper limit by pressing the Return key until the display reads *SL-H*. Next, use the Increment and Decrement keys to select the value. To set the lower limit, press the Return key until the display reads *SL-L*. Once again, use the Increment and Decrement keys to select the value. To return to the main level, press and hold down the Level key at least 3 seconds.

SETTING THE HYSTERESIS

To set the hysteresis value, press and release the Level key once. Next, press the Return key until the screen reads *HYS*. Set the hysteresis value by using the Increment and Decrement keys. To return to the main level press the Level key once.

Setup - If Using Heat Sealer (cont.)

Figure 11

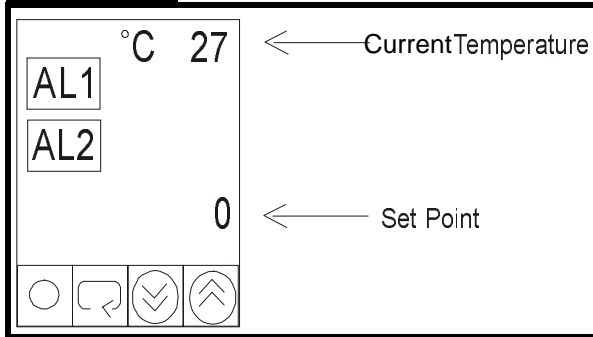

Default (Factory) Settings

1. Turn power on. All indicators light up briefly, then automatically display changes to Operation Level. See Figure 11.

Figure 12

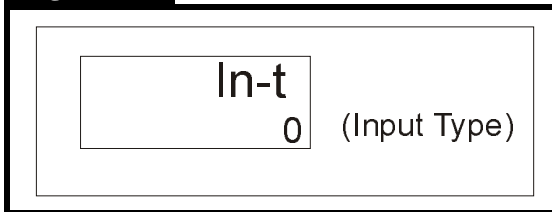

2. Press and hold the Level key (Figure 10, Ref. G) until display flashes and changes to that shown in Figure 12.

Figure 13

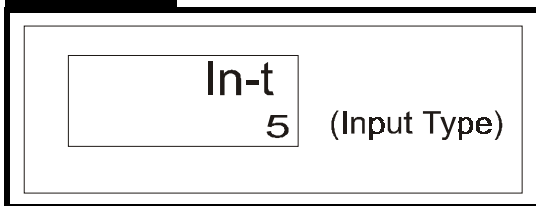

3. Press the Increment key (Figure 10, Ref. D) to change input type from 0 (zero) to 5. See Figure 13.

Figure 14

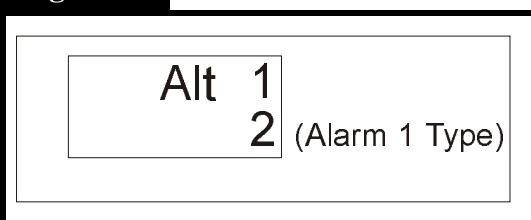

4. Press and release the Return key (Figure 10, Ref. F) several times until the display changes to that shown in Figure 14.

Figure 15

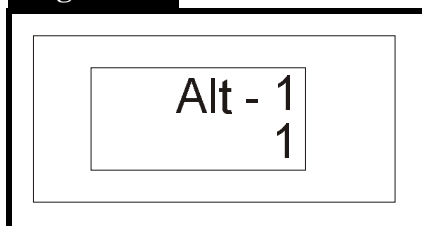

5. Press the Decrement key (Figure 10, Ref. E) to change the alarm type from 2 to 1. This disables alarm 1. See Figure 15.

Setup - If Using Heat Sealer (cont.)

Default (Factory) Settings (cont.)

Figure 16

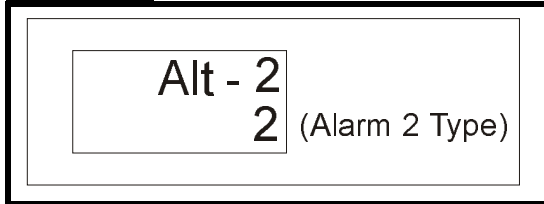

6. Press Return once to change the display to that shown in Figure 16.

Figure 17

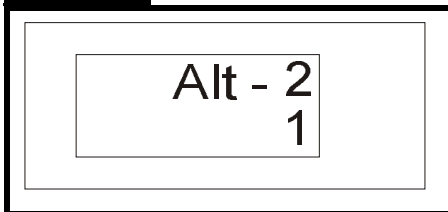

7. Press Decrement to change alarm type from 2 to 1. See Figure 17.

8. Press and hold the Level key until the screen changes to the display where every indicator lights up. The display will then change to Operation Level.

Setup - If Using Heat Sealer (cont.)

Default (Factory) Settings (cont.)

Figure 18

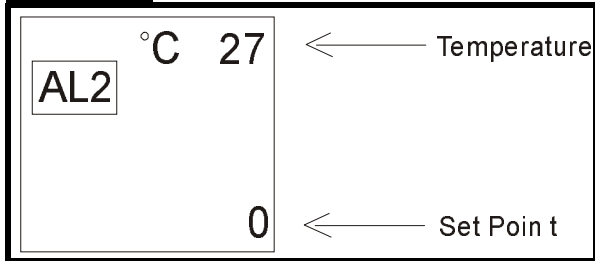

9. While in Operation Level, set Temperature Set Point and Alarm Values. See Figure 18.

10. Use arrow keys to set Temperature Set Point to 170. See Figure 18.

Figure 19

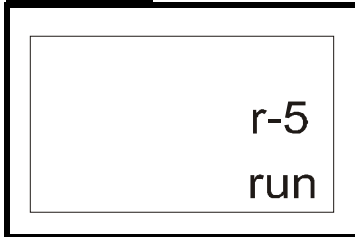

11. Press Return once. The display will change to that shown in Figure 19.

Figure 20

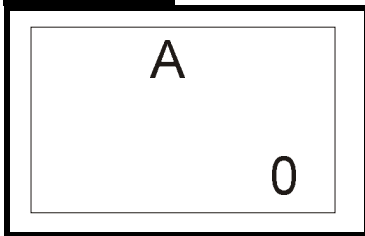

12. Press Return once. The display will change to that shown in Figure 20.

Figure 21

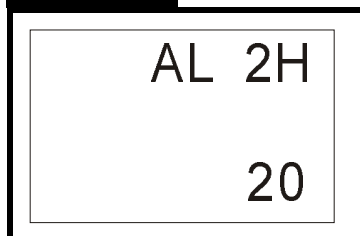

13. Use arrow keys to change Upper Alarm Level from 0 (zero) to 20. See Figure 21.

Setup - If Using Heat Sealer (cont.)

Default (Factory) Settings (cont.)

Figure 22

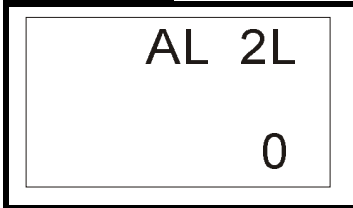

14. Press Return once. The display will change to that shown in Figure 22.

Figure 23

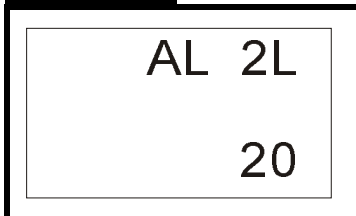

15. Use the arrow keys to change lower alarm level from 0 (zero) to 20. See Figure 23.

Figure 24

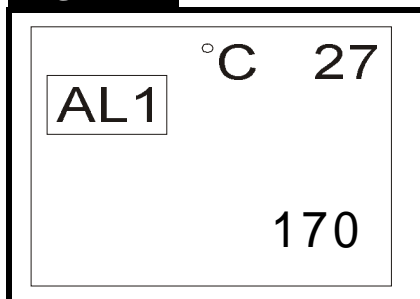

16. Press Return once more to return to standard operation. See Figure 24.

Setup - If Using Heat Sealer (cont.)

Default (Factory) Settings (cont.)

Figure 25

	<p>• Initial Setting Level control stoppe d</p> <p>Initial setting level enables users to specify their p conditions (input type, alarm type, control method, etc.)</p> <p> Hold down this button for at least 3 seconds. (To get from the Operation Level Initial Setting Level</p> <p> No. 1 display flashes when hold down f more than one second.</p> <p> Hold down this button for at least one second. (To get from the Initial Setting Lev) e Operation I</p>
--	--

Setup - If Using Heat Sealer (cont.)

Default (Factory) Settings (cont.)

Figure 26

↓

PV/SP

↓

Heater current monito
(Unit: A) *5

↓

Run = rUn
Stop = StoP

↓

Alarm value 1 * 4

↓

Alarm value upper limit 1 *

↓

Alarm value lower limit 1 *

↓

Alarm value 2 *4

↓

Alarm value upper limit 2 *4

↓

Alarm value lower limit 2 *4

↓

● **Operation level (Power ON)**

Hold down for at least 3 seconds to go back to the **Initial Setting level**.

No. 1 display flashes when hold dow for more than one second.

Press for less than one second to move from the **Operation level** to the **Adjustment level**.

4

Operation level should normally be used during operations.
Process value may be monitore d .

● **Protect level 1**

Hold and keys down for at least one second to move from the **Protect level** to the **Operation level**.

Operation/adjustment protect

↓

Initial/Communication protect

↓

Setting change protect

↓

This restricts movement to both the initial and

If ON, changes to setups by key operation are not allowed.

Setup - If Using Heat Sealer (cont.)

Default (Factory) Settings (cont.)

Figure 27

At	AT execute = AT cancel = oF	
Cnut	Communication Write *6	
Ct	Heater current monitor (Unit: A) *5	
Hb	Heater burnout (Unit: A) *5	
SP-0	Set point*7	
SP-1	Set point*7	
LnS	Temperature input shift (One Point Shift)	
LnSH	Input shift upper limit When Infrared Thermosensor ES1A selected (Two Point Shift)	
LnSL	Input shift lower limit When Infrared Thermosensor ES1A selected (Two Point Shift)	
P	Proportional band	
L	Integral time (Unit: secs) (0 to 3999)	
d	Derivative ti (0 to 3999)	m
C-SC	Cooling coefficient	
C-db	Dead band	
oF-r	Manual reset value (Unit: %)	
HYS	Hysteresis (heat) (0.1 to 999.9)	
CHYS	Hysteresis (cool)	

Adjustment level is the input made for PID control and correction settings.

Press less than one second to return to the **Operation level**.

*4: Applicable only to models with alarm functions.
 *5: Applicable only to models with the heater burnout alarm function.
 *6: Applicable only to models with a communications function.
 *7: Applicable only to models with an event function.
 *8: Controller does not operate during initial setting level. (Process will be stopped)

Use the following key operations for transition between levels:

- Operation level → Protect level + for at least one second
- Operation level → Adjustment level key for less than one second
- Operation level → Initial level key for at least three seconds

Setup - If Using Heat Sealer (cont.)

Refer to Figures 28 and 29 for the information below.

Figure 28

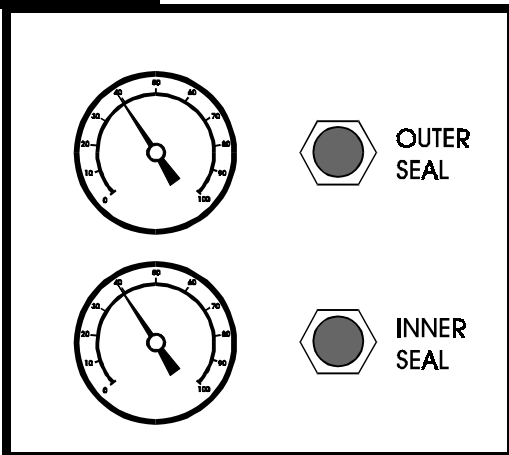
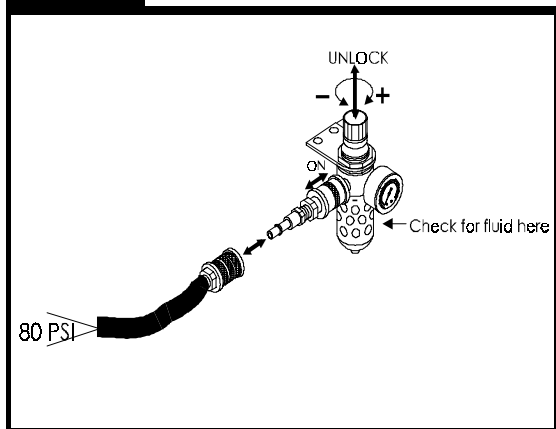

Figure 29



Seal Pressure Controls

The sealer mechanism contains two separate heat shoes which have independent controls for heat and pressure. The pressure gauges on the front of the TM-330 indicate the amount of air pressure in the sealing systems for each heat shoe. The controls for adjusting this air pressure are located directly beside the pressure gauges. Turning a control clockwise will increase the amount of pressure applied to the associated heat shoe.

Normally the two systems should be set at the same pressure, but they can be set differently if the seal characteristics dictate that one be set higher than the other.

When taping some very small SMD components, it may be necessary to decrease the seal pressure to reduce the shock applied to the carrier tape when sealing.

Attach Air Supply

Connect an air-supply hose (at least 80 PSI) to the input regulator on the left, rear side of the TM-330. Slide the air cut-off switch forward to apply air pressure to the TM-330. Pull up on the regulator control knob and turn it (clockwise increases pressure) until the gauge registers 80 PSI. Push the regulator control knob back down to lock it into position. To remove air pressure to the TM-330 at any time, slide the air cutoff switch back.

Setup - If Using PSA Sealer

Refer to Figure 30 for the information below.

Figure 30

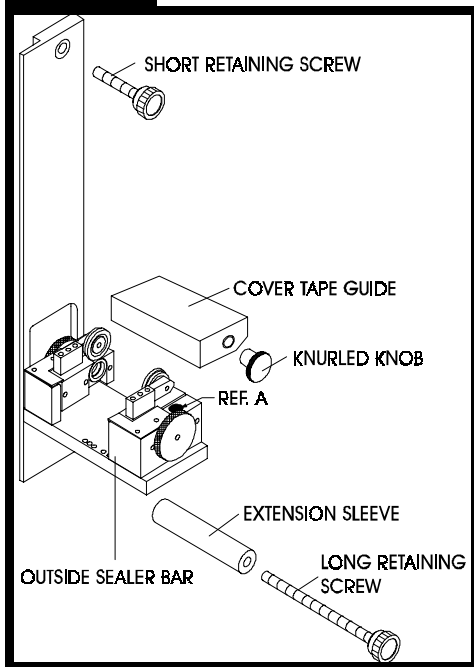

Mount PSA Sealer (Figure 30)

Remove the existing heat sealer and position the PSA sealer in place. Insert the short retaining bolt in the top hole on the sealer and the long bolt, through the extension sleeve, into the bottom hole. Tighten the retaining bolts, making sure the sealer is seated squarely.

Set Temperature Controllers

Set both temperature controllers so the set point (SP) is 30°C and the alarm value is at least 10. The temperature controllers will remain constant at a value close to 30°C.

Set Sealer Width (Figure 30)

Remove the retaining bolt from the sealer bar on the front of the sealer. Lift the bar free from the plate (there is a pin on each end of the bar). Replace the bar at the point where the width of the sealer track matches the width of the carrier tape being used. Replace and tighten the retaining bolt.

Select Cover Tape Guide (Figure 30)

There is a different cover tape guide for each tape width. The guides are the same ones used for the interchangeable heat sealers. When changing the sealer width, the cover tape guide must also be changed. To do so, remove the knurled, metal knob that secures it in place and slide it straight off. Mount the new cover tape guide once the sealer width has been changed.

Setup - If Using PSA Sealer (cont.)

Refer to Figure 31 for the information below.

Figure 31

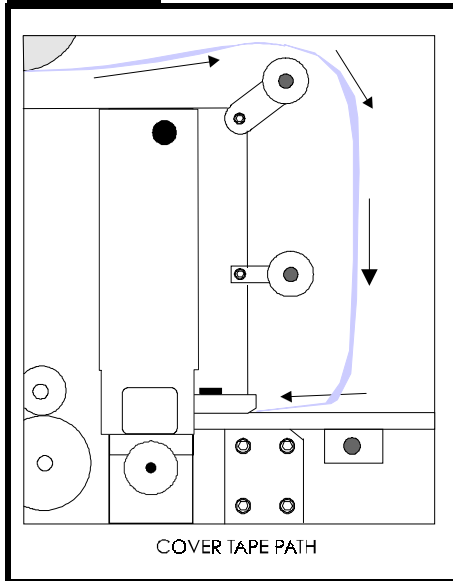

Load the PSA Cover Tape

Remove the large black knob from the cover tape spindle (loosen the brass set screw if necessary). Remove the spring, washer, and front plastic cover from the spindle. Place a reel of cover tape (correct width to match the carrier tape) on the reel center, so the tape unwinds to the right from the bottom of the reel. Replace the plastic cover, washer, spring, and black knob. Tighten the knob until there is some tension on the cover tape as it unwinds, but make sure the tension is not excessive. Tighten the brass set screw on the black knob to secure it in place.

Load the Carrier Tape

Remove the carrier tape quick lock from the hub and mount the bulk carrier tape reel on the hub (the sprocket holes on the carrier tape must be on the inside). Replace the quick lock and position it so the reel is supported and spins freely on the spindle. Trim the end of the carrier tape so it is clean and straight.

The loading track is adjustable for tape width. Set the track width to match the sealer mounted on the TM-330 by pulling out, or pushing in, evenly on both ends of the track. There are detents which will cause the track to lock in at each tape width.

Open the parts cover by lifting on the black knob and remove carrier tape guide #2 by unscrewing its black knob.

Guide the carrier tape under carrier tape guide #1 and into the loading track. The carrier tape should feed through the loading track easily. Lower the feed reel support arm if necessary to allow the tape to feed more easily into the loading track. Bring the end of the tape just up to cover tape guide #3.

Setup - If Using PSA Sealer (cont.)

Refer to Figures 32 and 33 for the information below.

Figure 32

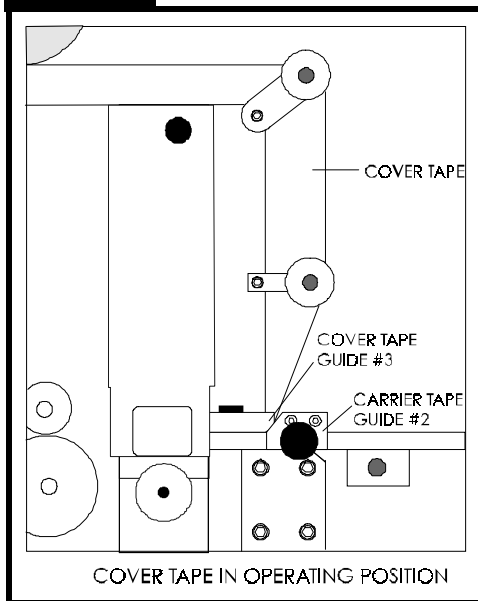

Load Tapes into the Sealer

Pull enough cover tape down so about 8" can be laid down on the carrier tape, sticky side down. Press the cover tape onto the carrier tape, so it is centered and running straight. Slide the two tapes under the cover tape guide, through the sealing wheels, and up to the drive sprocket on the left side of the sealer.

Lift the drive sprocket idler wheel up by pressing down on the left side of the idler arm. Move the carrier tape over the teeth on the drive sprocket and align the sprocket holes in the carrier over the teeth. Release the drive sprocket idler wheel. Make sure the teeth have engaged the holes in the tape. Replace carrier tape guide #2 and screw it down. Close the parts cover.

Cover Tape Alignment

Make sure the cover tape is in the tape groove in cover tape guide.

Check to be sure the tape is started into the tape guide to the left of the drive sprocket. Run tape through the sealer until the alignment of the cover tape to the carrier tape becomes constant. Carefully look at the cover tape to carrier tape alignment, at the point between the sealer and the drive sprocket, to decide whether it needs to be adjusted.

To move the cover tape in relation to the carrier, loosen the knob on cover tape guide and pull the guide slightly away from the adjustment dial, so the dial will turn freely.

Setup - If Using PSA Sealer (cont.)

Figure 33

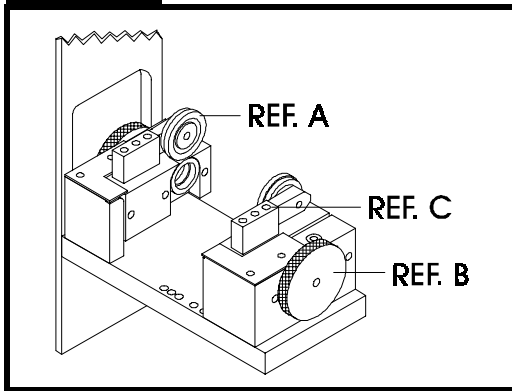

Sealer Wheel Alignment (Figure 33)

The small wheels that seal the cover tape to the carrier tape (Ref. A) need to be positioned so they will run directly over the sticky portion of the cover tape. The large knurled knobs on the sides of the sealer bars (Ref. B) are the adjustments for the position of these wheels.

It is easiest to move the position of the wheels while the tape is moving through the sealer. Begin advancing the tape through the sealer, then turn the knurled knob on the side of the sealer that needs to be moved. Turning the knob clockwise on the outside sealer bar will move the sealer wheel out toward the edge of the tape. Turning the knob clockwise on the inside sealer bar will move the sealer wheel in toward the center of the tape.

Sealer Wheel Tension (Figure 33)

The seal should appear as a consistent, solid line. If the seal appears ragged or broken, increase the tension of the seal wheels by turning the small screw that is just behind the wheel (Ref. C). Clockwise will increase the tension. The screw should not need to be turned very far (1/4 turn). Make sure that the rubber on the sealer wheels is not damaged.

If the sealer has become completely out of adjustment, turn the small screw behind the wheel (Ref. C) counterclockwise approximately three turns. Slowly turn the screw clockwise while spinning the top wheel. Stop adjusting when the bottom wheel starts spinning with the top wheel. Add the tape and do the final adjusting as explained in the above paragraph.

Operation

Refer to Figures 34 and 35 for the information below.

Figure 34

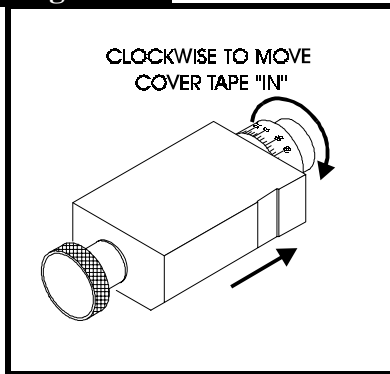
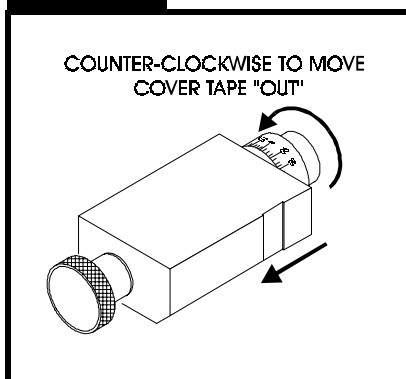

Figure 35



Initial Procedures

1. Set the take-up reel adjust control to 0 (fully counterclockwise). Turn the TM-330 main power switch ON.
2. Perform the taping assembly setup procedures described in this manual.
3. Set the counter module preset and prescale values.
4. Set the sealer controls at the appropriate levels. Wait for the temperature controls to stabilize near their set temperature.

Cover Tape Alignment

Make sure the cover tape is in the tape groove in cover tape guide #3.

Run some tape out by pressing on the foot switch. Watch the alignment between the cover tape and the carrier tape. Continue to run the tape out until the alignment becomes constant and does not shift. Look carefully at the alignment at this point to decide whether it needs to be adjusted.

To move the cover tape in relation to the carrier, loosen the knob on cover tape guide #3 and pull the guide slightly away from the adjustment dial so the dial will turn freely.

Turning the dial clockwise will move the cover tape closer to the sprocket holes on the inside edge of the carrier (10 divisions on the dial will move the tape .005 inches).

Turning the dial counterclockwise will move the cover tape closer to the outside edge of the carrier (10 divisions on the dial will move the tape .005 inches).

Push the tape guide back against the dial after the adjustment has been made and tighten the knob. Run the tape out again until the cover tape stops shifting and check the alignment. Repeat this procedure until the proper alignment has been achieved.

Operation (Cont.)

Peel Force

In most taping applications a peel force test is needed to determine the seal characteristics. Take as many peel force tests as are needed, while adjusting the sealer controls, to obtain the desired seal.

To Begin Taping

Leader/Trailer

Before beginning a production reel, you must decide how long the trailer and the leader need to be.

Trailer The strip of empty pockets needed at the end of the reel.

Leader The strip of empty pockets needed at the beginning of the reel to feed into a pick and place machine.

The trailer of each reel is taped first. After the cover tape alignment and any peel force tests are completed, run out enough sealed empty pockets to make the trailer. When the trailer is complete, go into the menu and reset the parts count to zero.

Tape Alignment

To ensure an accurate count, the first pocket in the loading track (left-most) must be a full pocket. That is, the left-most edge of the pocket must be aligned with the right edge of carrier tape guide #2 (Fig .3 ,Ref .W). If a full pocket is not showing, lift the carrier tape free of the drive sprocket and move it back until a full pocket is showing, then engage the carrier tape on the drive sprocket at that point.

Operation

Placing Parts

Starting with the left-most pocket, place a part in each empty pocket for the full length of the loading track. Close the parts cover (Fig. 2, Ref. V) if desired.

Press on the foot switch to advance the carrier tape through the taping assembly. Stop the tape advance prior to an empty pocket reaching the carrier tape guide #2 and refill the carrier tape in the loading track. Repeat until the trailer has advanced to a position where the end of the sealed tape reaches the take-up reel and attach it to the inside hub of the reel. Adjust the take-up reel tension with just enough tension to wrap the tape on the take-up reel. **DO NOT APPLY EXCESSIVE TENSION.** Use only enough tension to wrap the tape. Adjust tension as needed as parts are added.

Continue taping parts until the counter module reaches its Preset value and stops the tape advance.

To End Taping

Preset

When the End Count value in the software is reached, the TM-330 will stop. The last part to pass under carrier tape guide #2 will be the last part counted. Any additional parts in the loading track must be removed.

Leader

To continue advancing for leader purposes, press ESC to get back to the menu. Then re-enter the run state. This will allow you to advance beyond the step value.

Seal the desired number of empty pockets. When the last sealed empty pocket has cleared the drive sprocket, cut the tape just to the left of the sprocket.

On-Demand Seal

On occasion it may be necessary to reposition or replace a part in a tape that has already been sealed. Then the tape must be resealed. A provision has been made to cause the TM-330 to produce a complete seal stroke, including dwell time, without doing an advance move and without adding to the count.

After the part problem has been resolved, place the section to be resealed under the seal shoes. Then press the lower right asterisk (*) key. The TM-330 will execute a single seal. After this is done, re-position the tape as it was before the error was discovered, and continue normal taping operation.

TM-330 Empty Pocket Detector

If the EPD option is present is operates as follows. **NOTE: The EPD will only work if the system is advancing a single part per move. If multi-part advance is chosen the EPD will be automatically turned off.**

After a tape advance occurs, but before the count is increased, the system scans the empty pocket signal. If an empty pocket is under the sensor the TM-330 will place a logic low busy signal and a logic low empty pocket signal on the appropriate pins of the I/O connector. Further advance commands will be ignored until the empty pocket situation is resolved.

There are two ways to resolve the empty pocket situation: 1) Place a part in the empty pocket; the TM-330 will resume operation. 2) Press the ESC key; the TM-330 will ignore the empty pocket and continue operation. When operation continues the count will increase by one part since the pocket that was advanced under the sensor was not previously counted. The busy and empty pocket signals will be released at the same time.

TM-330

Maintenance Instructions

These instructions describe the maintenance procedures for the TM-330. Read all instructions before performing any maintenance procedures, and keep for future reference.



WARNING

Only qualified persons are allowed to perform maintenance procedures on the TM-330. Any maintenance procedures performed by unqualified persons could cause personal injury.





CAUTION

Only qualified persons are allowed to perform maintenance procedures on the TM-330. Any maintenance procedures performed by unqualified persons could cause damage to the equipment.

Maintenance Instructions

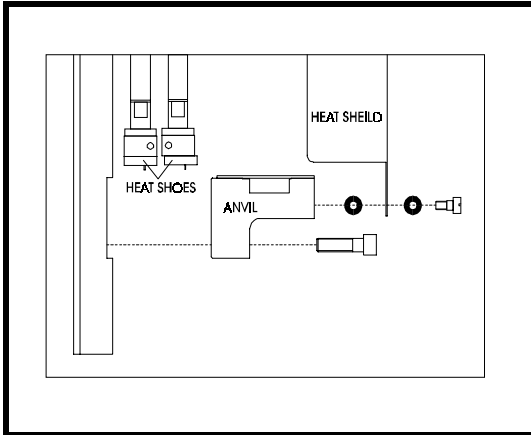
Figure 36



 **CAUTION**

Do not touch the heat shoe assembly when it is hot! It will stay hot enough to burn fingers for several minutes after the sealer has been turned off.

CAUTION

DO NOT USE ALCOHOL ON A HOT SEALER.

Heat Sealer

Heat sealer maintenance consists mainly of cleaning built-up residues from the heat shoes. These residues occur due to a mixture of dust, tape debris, and cover tape adhesive which accumulate during taping.

Remove the two bottom screws holding the heat shield to the sealer. Be careful not to lose the O-rings which are under the head of these screws and between the heat shield and the anvil.

Remove the two bolts which hold the anvil to the sealer assembly. Remove the anvil by sliding it to one side.

Clean the residues from the heat shoes by using a plastic or brass brush soaked in alcohol. **DO NOT USE A STEEL BRISTLED BRUSH.** If there are some tough spots, such as melted plastic, which are difficult to clean, the sealer can be heated by plugging it into the taping machine, and then scraped with the handle of a wood brush or some other wooden implement.

Alignment

If the seal becomes uneven, where one end of the heat shoe seems to be striking harder than the other, **DO NOT DISASSEMBLE THE HEAT SHOE ASSEMBLY!** To realign the heat shoes the sealer must be sent back to the factory.

O-Rings

There are five O-rings between the sealer assembly and the seal assembly upright which provide a seal between the two for the air pressure that drives the sealer. When changing sealer assemblies, check that these O-rings are in place and not damaged. When replacing, place a small amount of adhesive, such as super glue, on the O-ring before inserting into the recess. Make sure that the airway is not blocked.

Maintenance Instructions (Cont.)

Figure 37

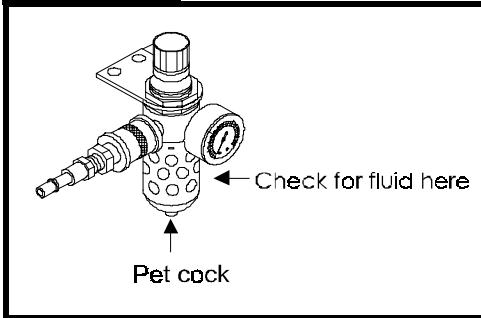

Loading Track

Occasionally, when the machine is stripped and the cover tape guide #3 is removed, brush the dust and debris from the track with a small, stiff bristled paint brush.

Cover Tape Guide #3

This may become coated with adhesive and dirt during taping. It is important to keep the tape groove clean for proper alignment of the cover tape. Clean the tape groove with alcohol and a cotton swab whenever it appears dirty.

Air Pressure Regulator

Inspect the air regulator for moisture accumulation. Check periodically, depending on quality of air, and press the pet cock on the bottom of regulator to release the fluid if moisture is present.

Figure 38

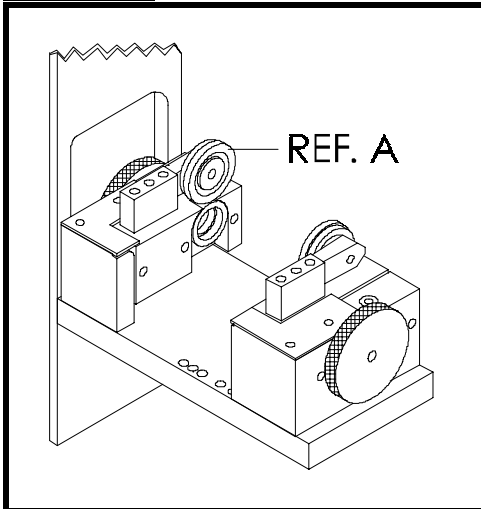

Universal PSA Sealer Maintenance

Clean the residues from the sealer assembly by using a cloth soaked in alcohol. Using a cotton swab soaked in alcohol, clean between the sealer wheels. Also, clean the entire surface of the plastic wheel.

CAUTION

Do not use solvents other than alcohol for cleaning the plastic wheels.

If during the cleaning process the sealer has become completely out of adjustment, turn the small screw behind the wheel (Ref. A) counterclockwise approximately three turns. Slowly turn the screw clockwise while spinning the top wheel. Stop adjusting when the bottom wheel starts spinning with the top wheel.

TM-330

Additional Features

Figure 1

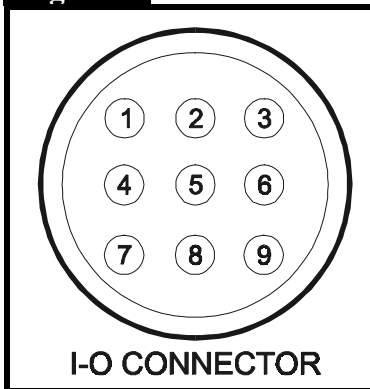

Figure 2

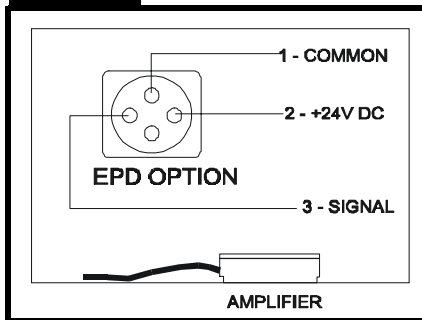
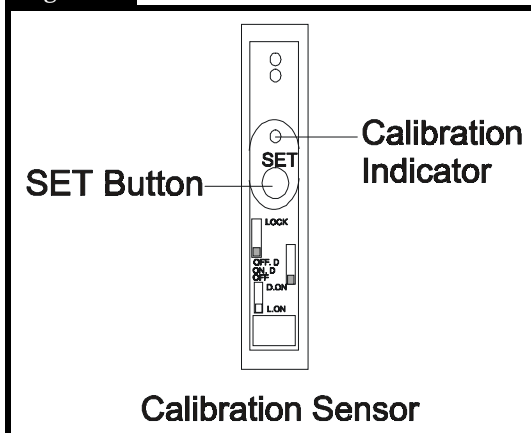

Figure 3



Low CoverTape Sensor

The low cover tape sensor output is at Pin 9 of the I-O Connector. Pin 4 is the DC logic common. When the cover tape is low the output will produce a logic low. This is an open collector device, which is connected to pin 6 by a 5.6k resistor. You can apply 5 - 24 volts to pin 6 to match your system logic.

Setting the Low CoverTape Sensor

Locate the low cover tape amplifier (see Figure 2). Place a reel of cover tape on the spindle blocking the sensor. Press and release the set button (see Figure 3). The yellow light will turn ON. Remove the cover tape. Press and release the set button again. The yellow light will turn OFF.

Figure 4

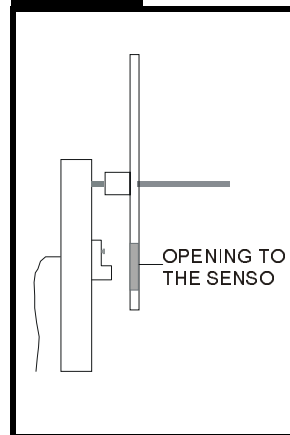

TM-330

Additional Features

Figure 5

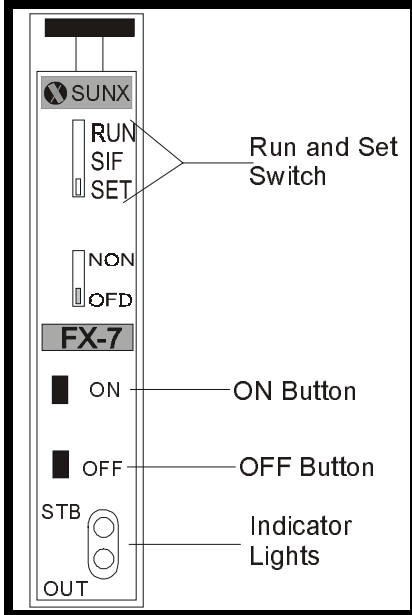

Empty Pocket Detector (EPD)

The empty pocket detector output is a Pin 3 of the I-O connector. When an empty pocket is detected the output will produce a logic low. This is an open collector device, which is connected to pin 6 by a 5.6k resistor. You can apply 5 - 24 volts to pin 6 to match your system logic.

Setting the EPD

Locate the EPD amplifier (Figure 5). Move the set switch to the set position. Position the sensor over an empty pocket and press the ON button. Then position the sensor over a full pocket and press the OFF button. Move the run/set switch to the run position.

Figure 6

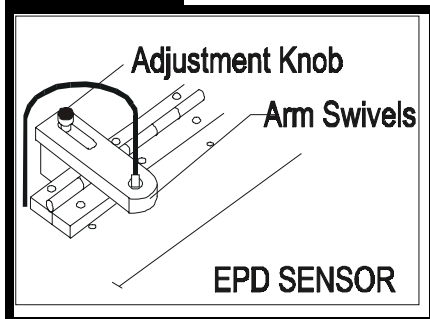

TM-330

Index

numerics

16 button keypad 9

A

adjustable loading track 8
advance 12
air pressure on/off switch 7
air pressure regulator 36
alarm functions 17
alarm indicator 17
alarm limits 17
alarm value 17
alignment 35
assembling procedure 6
attach air supply 26
attention 3

B

base plate assembly 6

C

carrier tape 22
carrier tape guide #1 8
carrier tape guide #2 8
carrier tape quick lock 8
carrier tape type 16
caution 4
connector j1 10
connector j2-3 10
connector j4 10
control module 6
control module base plate 6
control output indicator 17
controller operation 11, 12
count 11
cover tape alignment 29-31
cover tape guide #1 6, 8
cover tape guide #2 8
cover tape guide #3 8, 36
cover tape reel support 6
cover tape type 16
crushed hand 3, 7

D

dangerous voltage 3
decrement key 17
default (factory) settings 19-25
description of components 7-9

description of temperature controllers 17
display 17
drive sprocket 8
dwell 12
dwell time in milliseconds 16

E

encoder wheel 28

F

feed reel support arm 6
follower track support arm 6, 8
fuse (f1) 10

G

general controller operation 11
general seal setting information 16

H

heat sealer 35
heat sealer assembly 8
heat sealing 14-18
high temperature 3

I

idler arm 7, 21
idler wheel 8
increment key 17
initial procedures 31

J

jog 13

L

lcd display 9
leader 32, 33
led deviation indicator 17
level key 17
load tapes into the sealer 15, 28, 29
load the carrier tape 15, 28
load the cover tape 14, 28
load the heat sealer cover tape 14
loading track 36

M

main display 17
maintenance instructions 34-36
mode 13
mount heat sealer assembly 14
mount psa sealer 27
mount take-up reel 16

N

note 4

O

open book 3
operation 31-33
operation indicators 17
operation of temperature controllers 17-18
operator's instructions 5
o-rings 35

P

parts cover 8
peel force 32
peripheral plug-in 7
pitch 12
pitch setting guide 7
placing parts 33
power in (115 volt) 10
power switch 9
present data indicator 17
preset 33
pressure in psi 16
psa sealer setup 19-22
psa sealing 19-22
R
retaining bolt 19
return key 17
run 13

TM-330

Index

S

safety instructions 1
safety introduction 2
safety marking definitions 3,
4
seal assembly/motor up-right
plate 7
seal assembly connector 10
seal on/off switch 9
seal pressure adjust controls
7, 26
seal pressure gauges 7
seal wheels 22
sealer bars 22
sealer cooling 7
sealer wheel alignment 30,
31
sealer wheel tension 30
select cover tape guide 27
set point display 17
set sealer width 19
set temperature 19
set temperature controller 27
setting sealer width 27
setting target temperature 17
setting the hysteresis 18
setting the temperature con-
troller 18
setting up the machine 14-18
setting upper and lower limits
18
short retaining bolt 19
speed 12
sprocket idler wheel 21
starting points for seal con-
trols 16

T

take-up motor plug-in 8
take-up reel drive arm 6
take-up reel drive motor 8
take-up reel spindle 8
take-up tension 9
tape alignment 32
tape guide #3 7
tape reel spindle 7
temperature controls 9
temperature display 17
temperature in celsius 16
to begin taping 32
to end taping 33
trailer 32

U

universal psa sealer mainte-
nance 36

V

voltage select switch 10

W

warning 4

Additional Features - I/O Port

Effective 8/15/99

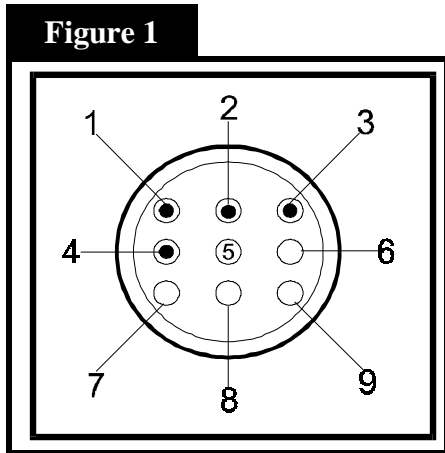

All output pins of the I/O port will be pulled up to the voltage level of pin 6, by 5.6k ohm resistors. Five volts to 24 volts may be applied to pin 6, to match your system logic. If no voltage is applied to pin 6, the pins will act as open collector devices.

The receptacle used is an AMP 206705-1 with 66103-4 male pins. The mate would be AMP 206708-1 plug, with 66105-4 socket pins.

Input

Pin 1 - external advance signal - a logic low starts advance. Pin 1 is internally pulled up to 5v. Use an OPEN COLLECTOR device to control this pin.

Pin 6 - +5 to +24 volt input from user.

Output

Pin 2 - empty pocket signal - a logic low indicates an empty pocket.

Pin 3 - ready/busy signal - a logic low indicates machine is busy.

Pin 4 - logic common.

Pin 5 - end of job - a logic low indicates the desired count has been reached.

Options

Pin 7 - cross track- this signal line will present an asymmetrical square wave when the carrier tape is moving. A steady state high or low logic value indicates a fault condition.

Pin 8 - carrier tape low - a logic low indicates fault condition.

Pin 9 - cover tape low - a logic low indicates fault condition.

Interfacing Information

The I/O port pins are referenced to the Pin 4 ground level.

When the TM330 is placed in the RUN mode at the beginning of a job, the control pins will be in the following states:

End of Job - Logic High
Ready/Busy - Logic High
EPD - Logic High
Advance - Logic High

The sequence of the handshake controls is as follows:

1. The *Advance* pin is pulled down to a logic low, for not less than 10 ms (milli seconds).
2. The TM330 will set the *Ready/Busy* line *low* and begin the advance process. The *Ready/Busy* line will remain low until the advance is done and the heat sealing dwell time has completed. While the TM330 is running this process, all advance commands are ignored. Upon completion of the advance/seal sequence, the *Busy/Ready* line will return high and the next advance will be accepted.
3. When the preset stop value is reached, two things happen that can be used as *Done* indicators.
 - The *Busy/Ready* pin remains at a logic low.
 - The *Job Completed* pin switches to a logic low.

Releasing the *Busy/Ready* and *Job Completed* signals is accomplished by pressing the ESC key, and re-entering the RUN mode.

TM 220/330/440

I/O Connector Considerations

THE DC SYSTEM WITHIN THE TM-220/330/440 IS ISOLATED FROM THE AC SYSTEM. DC GROUND IS NOT CONNECTED TO EITHER CHASSIS GROUND OR AC NEUTRAL.

TO SAFELY CONNECT YOUR CONTROL SYSTEM DC GROUND TO THE TMXX0 I/O PIN 4 DC GROUND. YOUR CONTROL SYSTEM DC GROUND SHOULD ALSO BE ISOLATED FROM YOUR AC SYSTEM. HOWEVER, YOUR CONTROL SYSTEM DC GROUND MAY SAFELY BE CONNECTED TO CHASSIS GROUND, IF NECESSARY.

IF THE AC SYSTEM USED TO POWER THE TMXX0 IS A SINGLE PHASE SYSTEM, WHERE THE NEUTRAL LEG CONNECTS TO THE CHASSIS GROUND AT THE FUSE BOX, DC GROUND COULD ALSO BE CONNECTED TO AC NEUTRAL WITHOUT PROBLEM.

WARNING IF THE AC SYSTEM USED TO POWER THE TMXX0 IS A TWO PHASE SYSTEM, (NEITHER LEG CONNECTS TO CHASSIS GROUND AT THE FUSE BOX) ONLY THE CHASSIS GROUND CAN BE USED AS A DC COMMON. CONNECTING DC COMMON TO EITHER POWER LEG WILL RESULT IN SEVERE DAMAGE TO THE TMXX0.

PIN 1 IS THE EXTERNAL ADVANCE PIN. THIS PIN IS TO BE ACTIVATED BY AN OPEN COLLECTOR DEVICE. PIN 1 IS INTERNALLY PULLED UP TO 5 VDC.

PIN 6 OF THE I/O CONNECTOR IS USED TO SUPPLY A PULLUP VOLTAGE TO THE OUTPUT SIGNAL PINS. 5--24VDC MAY BE APPLIED AS NEEDED TO MATCH THE LOGIC SYSTEM.

PINS 2,3,5 ARE OPEN DRAIN MOSFETS WITH A 5.6K PULLUP RESISTOR TO PIN 6. THESE ARE CONTROLLED BY THE TMXX0 SYSTEM. EACH PIN CAN SINK 200MA.

PINS 7,8,9 ARE ALSO PULLED UP TO PIN 6 WITH A 5.6K RESISTOR. THESE PINS ARE USED TO SUPPLY A LOGIC PULLUP TO EXTERNAL DEVICES, WITH OPEN COLLECTOR SIGNALS, WHICH ARE PASSED THROUGH THE TMXX0.

ALL ACTIVE LOGIC SIGNALS ARE NOW LOGIC LOW. FOR EXAMPLE, THE BUSY SIGNAL WILL BE LOW WHILE AN ADVANCE IS IN PROGRESS.

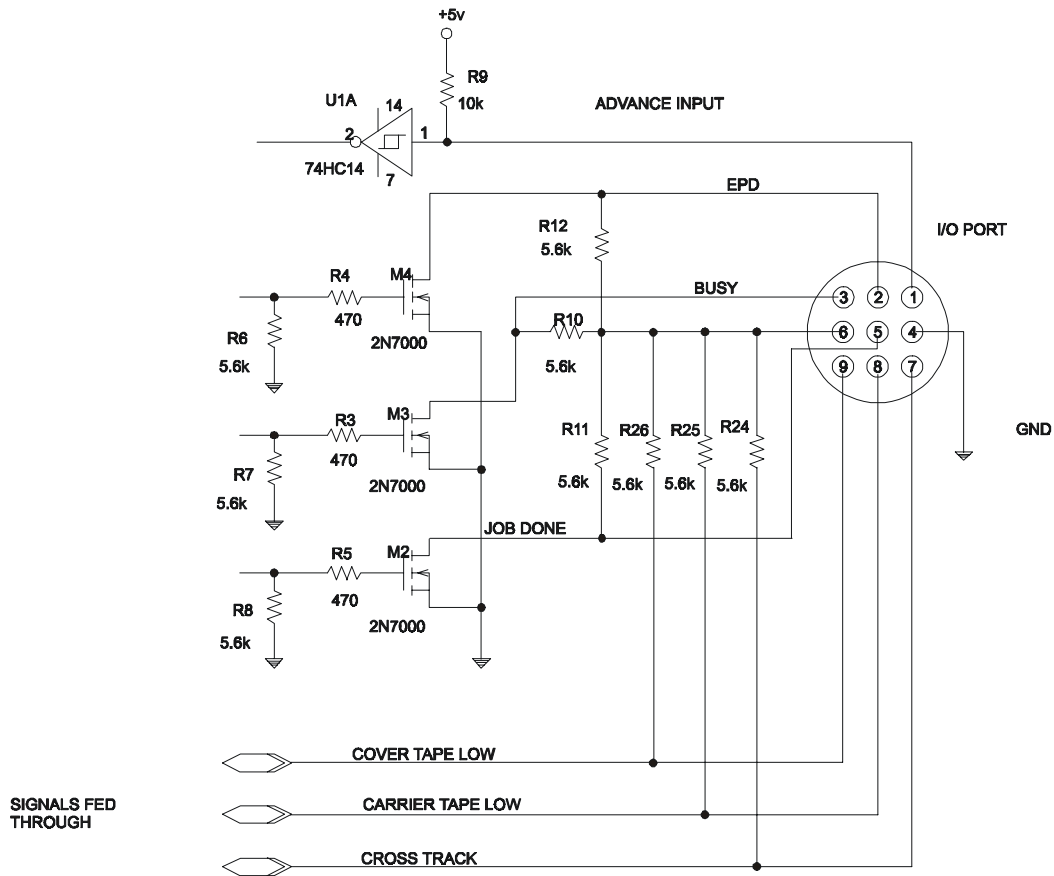

TM2220/330/440 INTERNAL

V-Tek System Interface

EXAMPLE USER INTERFACE

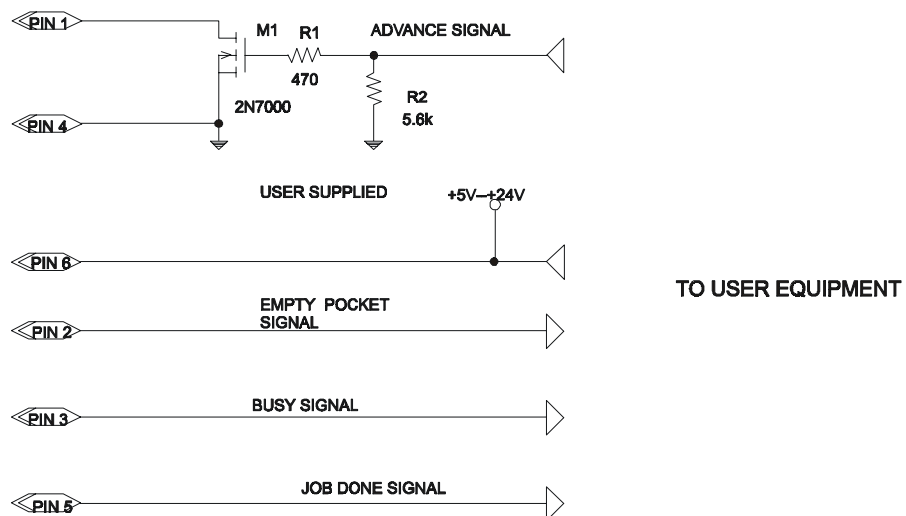

TM 220/330/440

Power Hookups

TM-220/330/440 POWER HOOKUP AS SEEN FROM PANEL REAR

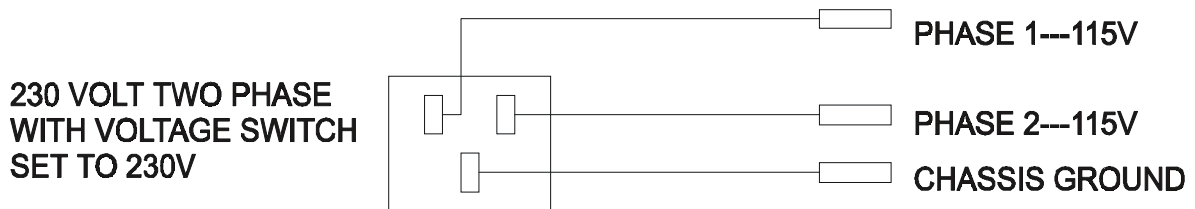
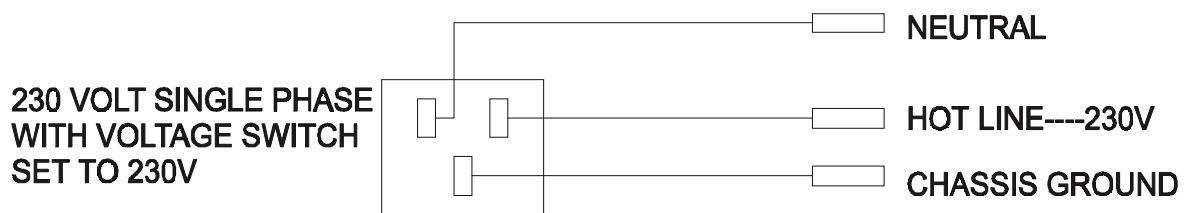
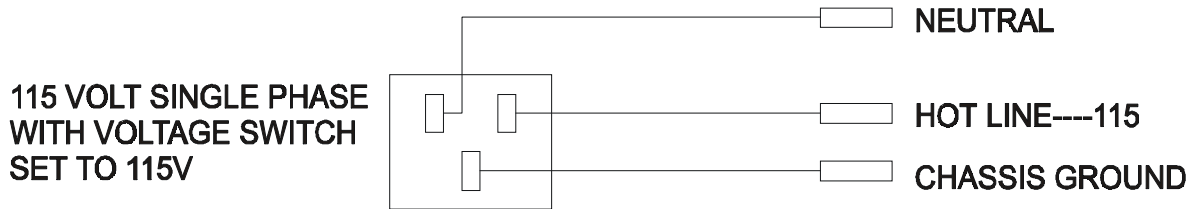

Set the EPD

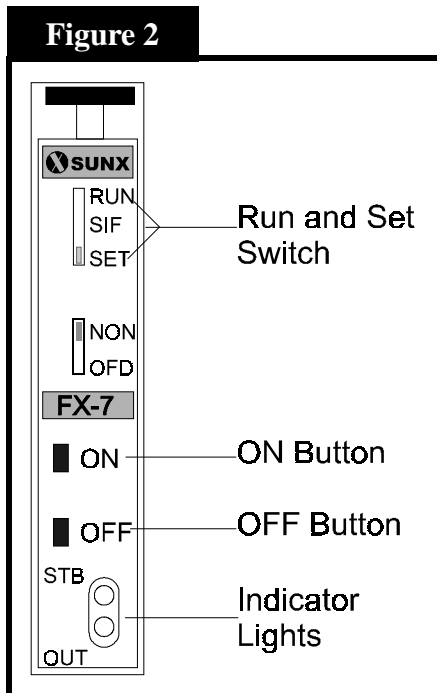

The empty pocket detector output is at Pin 3 of the I-O connector. When an empty pocket is detected the output will produce a logic low. This is an open collector device, which is connected to pin 6 by a 5.6k resistor. You can apply 5 - 24 volts to pin 6 to match your system logic.

To activate the EPD sensor, open the Setup Choices screen in the controller. Under **3>Advance**, choose **1**; under **7>Mode** choose **4>EPD on**. Make sure the pitch is set correctly for the carrier tape being used.

On the amplifier, move the run/set switch to the **SET** position. Position the sensor over an empty pocket and press the **ON** button. The position of the sensor can be adjusted by moving the support arm into the desired position over the track. Then position the sensor over a full pocket and press the **OFF** button. Move the run/set switch to the **RUN** position.

The sensor must be reset for each new type of part to be taped.

Setup Instructions for Optional Keyence FS-V11 Sensor

Figure 1

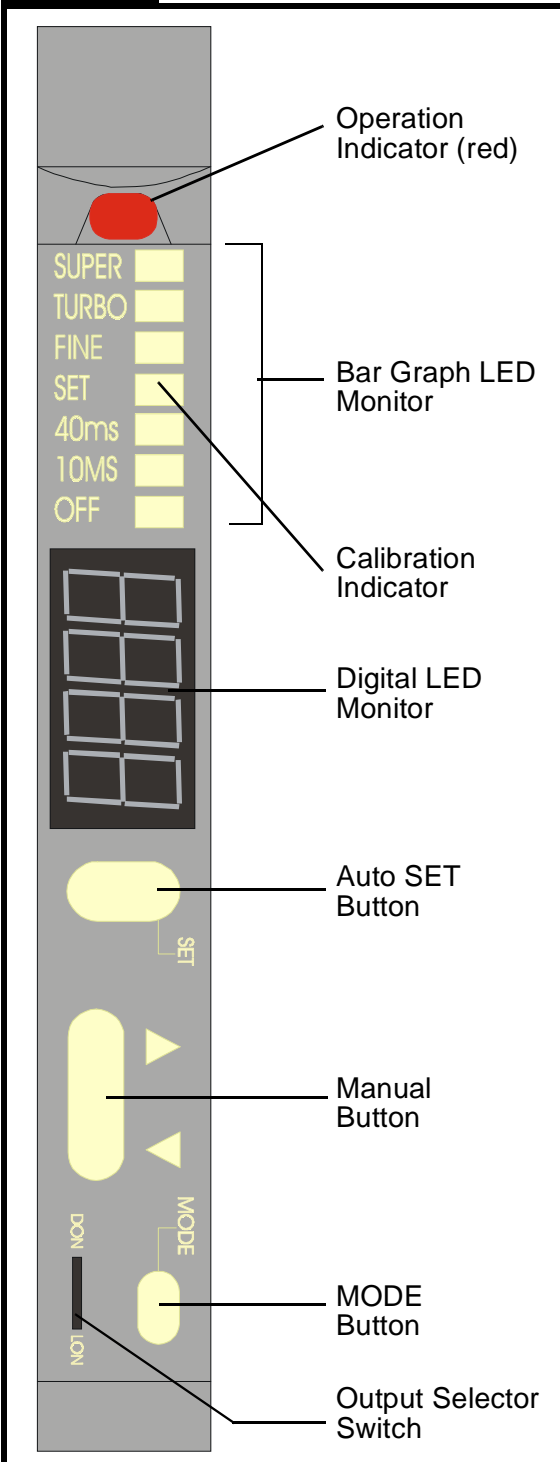

This sensor can be used for several purposes, including as an empty pocket detector or as a low cover tape sensor.

CALIBRATING THE SENSOR

There are several methods of calibrating the sensor. The method used depends on the target condition. After the sensitivity is set, the setting value flashes twice.

AUTOMATIC CALIBRATION

Stationary Target

Two Point Calibration (most common). Used for the low cover tape application.

1. Set the output selector switch to D.ON.
2. Place a roll of cover tape or other target in front of the sensor. Press and release the SET button. The calibration indicator will light.
3. With no cover tape or other target present, press and release the SET button again.

Positioning Calibration

1. With no target present, press and release the SET button. The calibration indicator will light.
2. Place a target in front of the sensor in the position it is to be stopped.

3. Press the SET button and hold it for at least 3 seconds until the calibration indicator flashes. Release the SET button. The calibration indicator light will go off.

Moving Target

Fully Automatic Calibration

1. Move a target through the optical field of the sensor while pressing and holding the SET button.
2. Confirm that the calibration indicator is flashing.
3. Release the SET button. The calibration indicator light will go off.

Setup Instructions for Keyence FS-V11 Sensor (Cont.)

Maximum Sensitivity Setting

When the sensor is used to detect a target with other objects in the background, the sensitivity is set to the maximum value at which the target is detected and the background objects are not.

1. With a target and background objects in front of the sensor, press and hold the SET button for at least 3 seconds.
2. Confirm that the calibration indicator is flashing.
3. Release the SET button. The calibration light indicator will go off.

MANUAL CALIBRATION

The Manual button is used for this procedure (Figure 2). The current value will be displayed on the digital LED monitor. The display begins flashing two seconds after the manual button is pressed.

Received Light Intensity Display

Press the up or down arrow once. The setting value will start flashing. While it is flashing, the value can be changed by pressing the up or down arrow.

To Increase the Sensitivity:

Press the up arrow. The numeric value decreases, as shown in Figure 3.

To Decrease the Sensitivity:

Press the down arrow. The numeric value increases, as shown in Figure 4.

The current value will appear after two seconds.

Figure 2

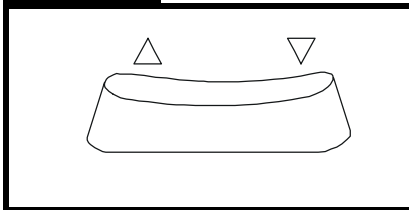

Figure 3



Figure 4



Setup Instructions for Keyence FS-V11 Sensor (Cont.)

Figure 5

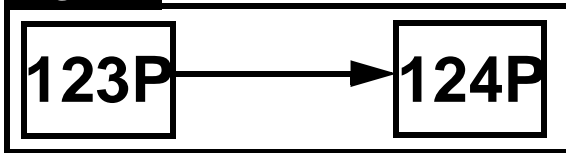
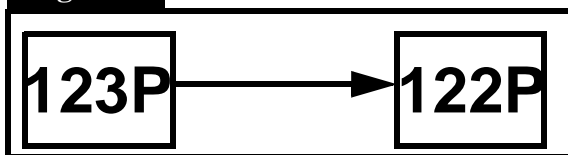

Figure 6



Excess Gain Display

Press the up or down arrow once. The setting value will start flashing. While it is flashing, the value can be changed by pressing the up or down arrow.

To Increase the Sensitivity:

Press the up arrow. The numeric value increases, as shown in Figure 5.

To Decrease the Sensitivity:

Press the down arrow. The numeric value decreases, as shown in Figure 6.

The current value will appear after two seconds.

Locking the Operation Button

Hold down the up or down arrow and MODE simultaneously for at least 3 seconds. The digital display will flash with *LOC*. The display data or the output method can be changed while the setting value is displayed.

Repeat the same procedure to unlock the operation button. The display will flash the message *unL*.

Power Selection

The current power mode is displayed by a lighted indicator on the bar graph monitor. To change the mode, press and hold MODE for at least 3 seconds, then press the up or down arrow to select the desired mode.

Timer Selection

The current output timer mode is displayed by a lighted indicator on the bar graph monitor. To change the mode, press and hold MODE for at least 3 seconds, then press the up or down arrow to select the desired mode.



751 Summit Avenue
Mankato, MN USA 56001

www.vtekusa.com

Your questions are important to us. For customer service, please call or write:

Phone: 507-387-2039 Extension 145
Email: vteksvc@gotocrystal.net

Please provide the machine model and serial numbers with all inquiries.

To order spare parts, please call:

Phone: 507-387-2039 Extension 133

For tape and reel supplies, please call:

Phone: 507-387-2039 Ask for CPM Sales

NOTES

TM-330

Taping Machine Operator's Manual

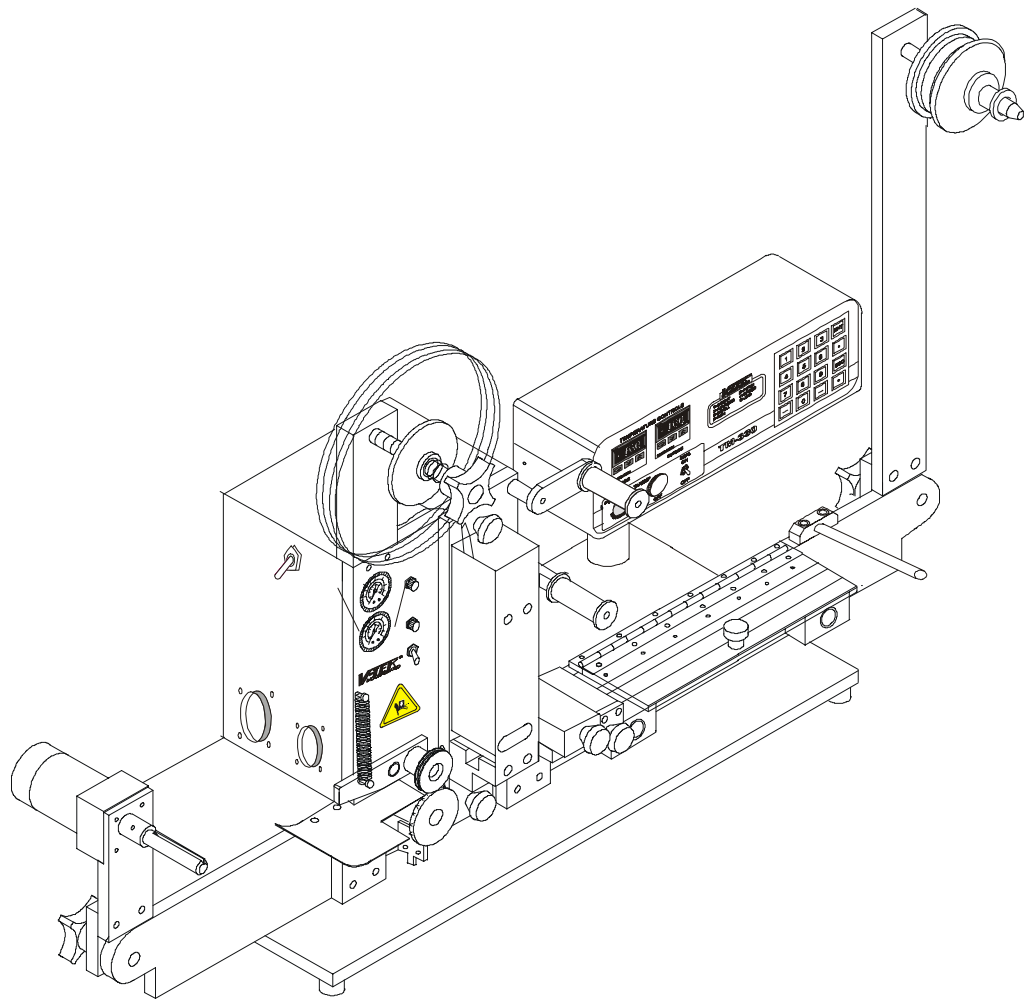



**751 Summit Avenue
Mankato, MN 56002**

(507) 387-2039 FAX: (507) 387-2257

www.VTEKUSA.com
E-Mail: Info@VTEKUSA.com

